

Six strategies for combating abrasion in your low-speed blender — Part II

Heinz Feibert and Bill Purse

Charles Ross & Son Company

Abrasion problems aren't confined to high-speed mixing equipment: They also affect low-speed blenders — namely, ribbon blenders and vertical cone screw blenders¹ — with equally serious results. This two-part article outlines six strategies for fighting abrasion in your low-speed blender. Part I (June 2000) covered the first two strategies as well as low-speed blender basics and tips for assessing the wear potential of your abrasive materials. Part II covers the final four abrasion-fighting strategies.

Strategy 3: Protect the shaft

To prevent particles from penetrating a ribbon blender's stuffing box and wearing the shaft, you can add a lantern ring inside the stuffing box, as shown in Figure 1. The lantern ring fits around the shaft and is packed with compressible (often Teflon) packing material to form a tight seal against the shaft. An air connection in the lantern ring is linked to a supply of 10- to 15-psi compressed air. During blending, air passes through the connection, out of the stuffing box, and toward the blender trough to entrain particles that have entered the stuffing box and direct them back into the trough, thus protecting the shaft from abrasive wear.

You can further protect the shaft by adding a hardened sleeve to the shaft where it passes through the stuffing box. The sleeve can be made of an engineered composite such as tungsten carbide or stellite.

Strategy 4: Think vertical

Keeping abrasive materials out of a ribbon blender's submerged shaft seal in the stuffing box is critical — and can be a problem even when the stuffing box is air-purged with a lantern ring. The material accumulating around the stuffing box can also pose cleaning and contamination problems, especially in sanitary applications such as food and pharmaceutical blending and in applications blending colorants or pigments. In extremely abrasive applications, the accelerated wear on the ribbons and trough, even when they're made of heavy-gauge steel, can be unacceptable. The best answer for these problems can be to use a vertical cone screw blender rather than a ribbon blender.

Because the ribbon blender is horizontal, the shaft seal is always submerged in material and subject to abrasive wear. But the vertical cone screw blender's drive assembly is located above the vessel, so abrasive particles have no way to reach the shaft seal.

For handling abrasive materials, you can also select a vertical cone screw blender with an "unsupported" screw, as shown in Figure 2. In this configuration, the drive assembly suspends the screw without any support bearing at the screw's bottom as the screw revolves on its own axis and orbits the vessel. Eliminating this support bearing eliminates a notorious source of maintenance problems. It also makes complete blender discharge and cleaning faster and easier, because the vessel's lower end is free of obstructions.

Other reasons to consider a vertical cone screw blender are to provide gentler blending with less abrasive wear, to save energy, and to save floor space.

Gentler blending with less abrasive wear. The vertical cone screw blender blends more gently than a ribbon blender and can sharply reduce friction and abrasive wear. Vessel geometry is one reason: In the cone screw blender, materials gently lifted by the screw tumble and slide down along the vessel wall, as shown in Figure 3. In the ribbon blender, the ribbons impel the materials laterally along the vessel's length and produce a more violent, high-energy blending action.

The choice of a ribbon blender or vertical cone screw blender often depends on your available floor space and headroom.

The vertical cone screw blender's tip speed (also called *peripheral speed*) is also slower, applying less mechanical energy to the materials. For example, a 14-inch-diameter screw in a 500-cubic-foot cone screw blender operates with a tip speed of 220 fpm (that is, surface feet per minute). In a ribbon blender with the same working volume, the 72-inch-diameter ribbon agitator turns at a peripheral speed of about 300 fpm — almost 50 percent faster.

Energy savings. The vertical cone screw blender also consumes substantially less energy than a ribbon blender. Consider a typical cone screw blender and ribbon blender, each with a 100-cubic-foot working capacity. In the cone screw blender, the screw is driven by a 20-horsepower motor and the orbital arm by a 2-horsepower motor. The ribbon blender's agitator is driven by a 50-horsepower motor, drawing more than twice as much power.

Floor space savings. The choice of a ribbon blender or vertical cone screw blender often depends on your available floor space and headroom. The ribbon blender — even with a compact drive — is a horizontal machine with a large footprint. The cone screw blender is a vertical unit that consumes much less floor space. When floor space is tight and you have enough headroom, the cone screw blender is a good alternative for increasing your blending capacity.

The bottom line when choosing a blender is to test both types. The tests (further described in the later section "Working with your blender manufacturer") should be run in a controlled laboratory setting, most likely in the manufacturer's test facility, using the materials you'll be blending. Surprises often come to light during testing — and when they do, you're the beneficiary.

Strategy 5: Upgrade to wear-resistant steel

As you consider which blender is right for your application, be prepared to discuss steel grades with the blender manu-

facturer. Upgrading from carbon steel or another conventional steel to provide greater wear resistance can make an enormous difference in your blender's durability. This will increase your up-front cost, but perhaps by less than you expect. In some cases, the higher-quality steel's added hardness and strength will allow you to reduce its gauge.

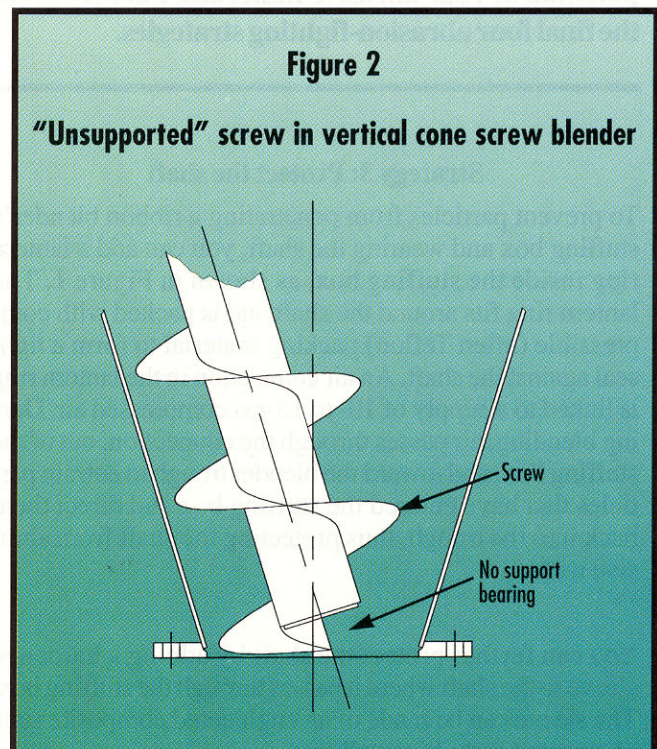
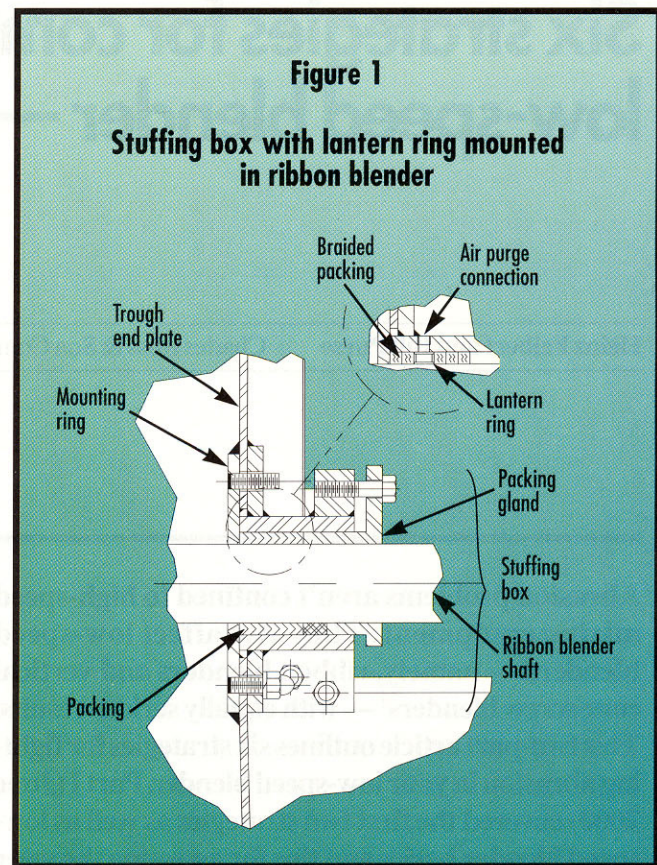

You don't have to be an expert in steel. But you must at least be aware of the steel quality and gauge specified for the blenders you're considering. Many wear-resistant alloy steels, available in a variety of grades, offer greater "formability" (that is, ease of fabrication) and hardness than ordinary carbon steel.² Steel surface hardness is typically measured in Brinell Hardness Numbers (BHN). Steel for nonabrasive applications is typically specified at 200 to 250 BHN, while steel for abrasive applications should be specified between 300 and 500 BHN.

Don't presume that one low-speed blender type is right for you until you test various blenders with your materials in the manufacturer's test lab.

Two blenders that appear to be comparable can actually be quite different because the steel specified for each is different — which affects the working life you can reasonably expect from each blender. For this reason, if you're thinking of buying a used or refurbished blender for mixing abrasive materials, make sure you know what kind of steel it's made of before you buy. Otherwise you may watch your investment wear away overnight.

The blender manufacturer won't regard wear-resistant steel as a perfect solution because many grades of this steel are brittle and hard to handle during fabrication, driving up the blender's cost. The manufacturer must balance the value of wear resistance against the need for a steel grade that will allow high-quality, efficient fabrication.

Strategy 6: Apply wear-resistant coatings to components

Depending on your application's abrasiveness, you may want to apply a wear-resistant coating (also called *hardfacing*) to components in the low-speed blender. Except in a blender handling extremely abrasive materials, the coatings are generally applied only to portions of the ribbons, screw, or vessel wall. These coatings are generally cost-effective when concentrated where they're needed most — on the blender surfaces subject to intense abrasive action. For example, in a vertical cone screw blender, a wear-resistant coating would be applied only to the screw's leading edge.

Wear-resistant coatings include tungsten carbide and stellite. Tungsten carbide is a strong shield against abrasive wear that has been around for years. Stellite is one of a family of cobalt-chromium-tungsten-based alloys with extremely wear-resistant properties.

Stellite is available in several grades with excellent hardness, smoothness, and uniformity. Even at high tempera-

Figure 3

Blending action in vertical cone screw blender

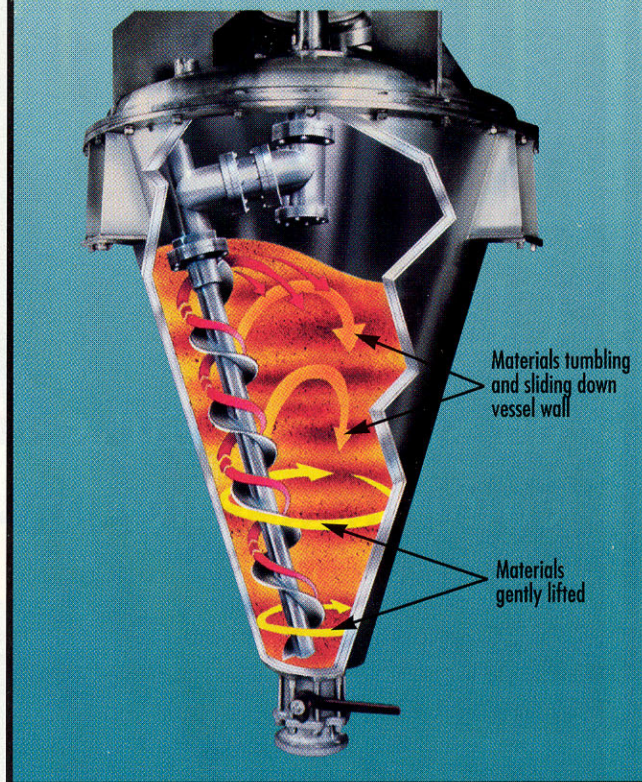

tures, stellite is extremely resistant to wear, galling, corrosion, and erosion. Stellite coatings can be applied in several ways. Depositing them in a high-velocity spray produces an especially smooth, uniform surface. Stellite can also be applied by welding, using stellite supplied in the form of a welding rod, and then ground to a smooth finish.

Tungsten carbide and stellite are also available in pre-formed wear plates that can be welded onto critical areas in your blender. However, you should use the plates with caution because crevices at the plate edges collect debris, making the plates hard to keep clean.

Working with your blender manufacturer

To meet today's market demands, blending equipment must blend faster. The equipment must also last longer, especially when it handles abrasive materials. And in many cases it must be more versatile, such as for applications requiring blending and vacuum drying in one vessel. Ensuring that your low-speed blender reaches this level of productivity requires a productive relationship with the blender manufacturer.

Start by finding a blender manufacturer who welcomes two-way communication and wants to do more than just fill an equipment order. As you work with the manufac-

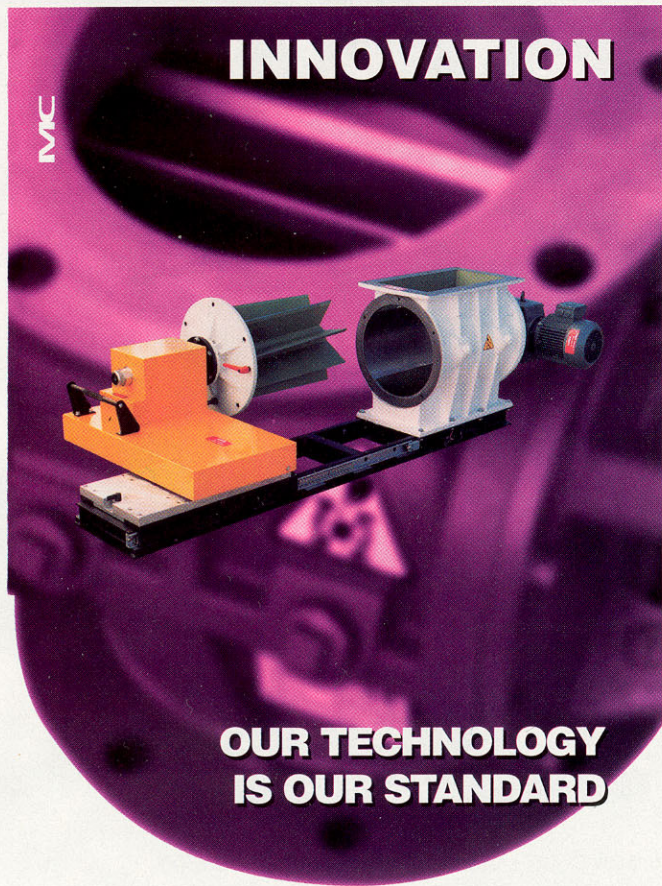

What is an innovation for the other people is a recognized production standard for us. Quick disassembly rotary valve with longitudinal and trasversal pulling out of the rotor. Safety guards to protect slide-ways and mechanical parts. Manufactured in mild steel and stainless steel.



ROTARY DRUM DIVERTER VALVE VPTL

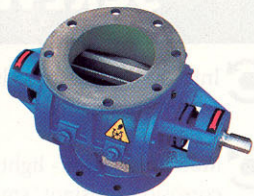

ROTARY VALVE UPR - UNI PN10 ANSI 150 FLANGES



BUTTERFLY VALVE VPF



our sole agent for North America:



Ocrim America, Inc.
5095 Nathan Lane North
Minneapolis, Minnesota
U.S.A. 55442-3208
Telephone: (612) 557-6411
Fax: (612) 557-6632



www.olocco.it - E-mail: olocco@olocco.it

Write in PBE #60

turer during the design process, make sure everyone involved thoroughly understands the characteristics of the materials you're blending and your process parameters. Don't conceal too many details about your application or your business goals from the manufacturer's design engineer. You'll be surprised to discover how much more the engineer can contribute to your blender's design when you provide more information.

When assessing competing engineering proposals from different blender manufacturers, meticulously compare design elements, right down to the grade and gauge of all blender construction materials and the long-term value they represent.

Don't presume that one low-speed blender type is right for you until you test various blenders with your materials in the manufacturer's test lab. Weigh each blender's short-term cost against its long-term value for your application.

Once you've narrowed your choice, the last and often most important step is to test the blender again in the manufacturer's test lab to optimize your blending technique. This well-controlled setting is the perfect place to fine-tune your process parameters before you install the blender in your plant. **PBE**

References

1. This article concentrates on low-speed blenders equipped with agitators. For information on other low-speed blenders or general mixing and blending equipment, see the next section, "For further reading."
2. For more information on selecting wear-resistant steel, contact the authors.

For further reading

Find more information on blenders in articles listed under "Mixing and blending" in *Powder and Bulk Engineering's* comprehensive "Index to articles" (in the December 1999 issue and at www.powderbulk.com).

Heinz Feibert is product manager for ribbon blenders, vertical cone screw blenders, and custom-built mixers and tanks at Charles Ross & Son Company, Box 12308, Hauppauge, NY 11788; 800/399-4569, fax 631/234-0691 (hfeibert@rossmixing.com). His expertise includes engineering, manufacturing, and pressure vessel design and fabrication, and he's been with the company for 17 years. Bill Purse is senior engineer at Ross, specializing in product design and standards, applications, and technical service. He's been with the company for 13 years.